

6C-17
 FILED
 GREENVILLE, CO. S. C.
 MAY 19 4 35 PM '77
 DONNIE S. TANKERSLEY
 R.M.C.

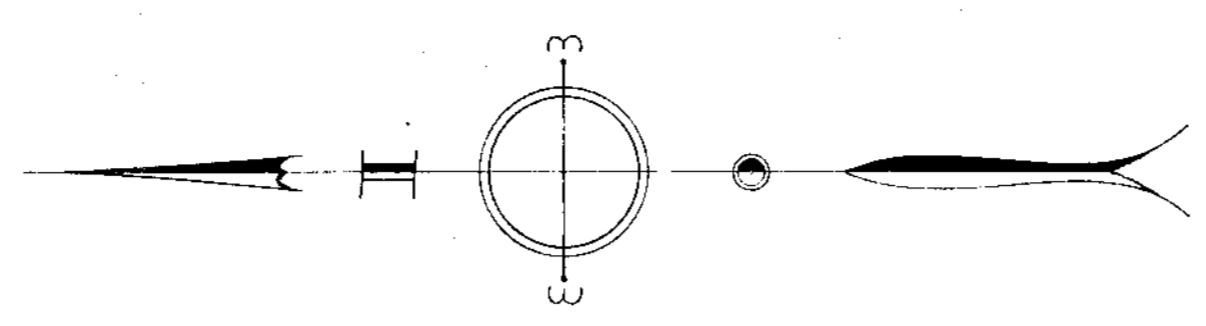

6C-18
 FILED
 GREENVILLE, CO. S. C.
 MAY 19 4 35 PM '77
 DONNIE S. TANKERSLEY
 R.M.C.
 31577

Scale 1" = 100' Horizontal
 1" = 10' Vertical

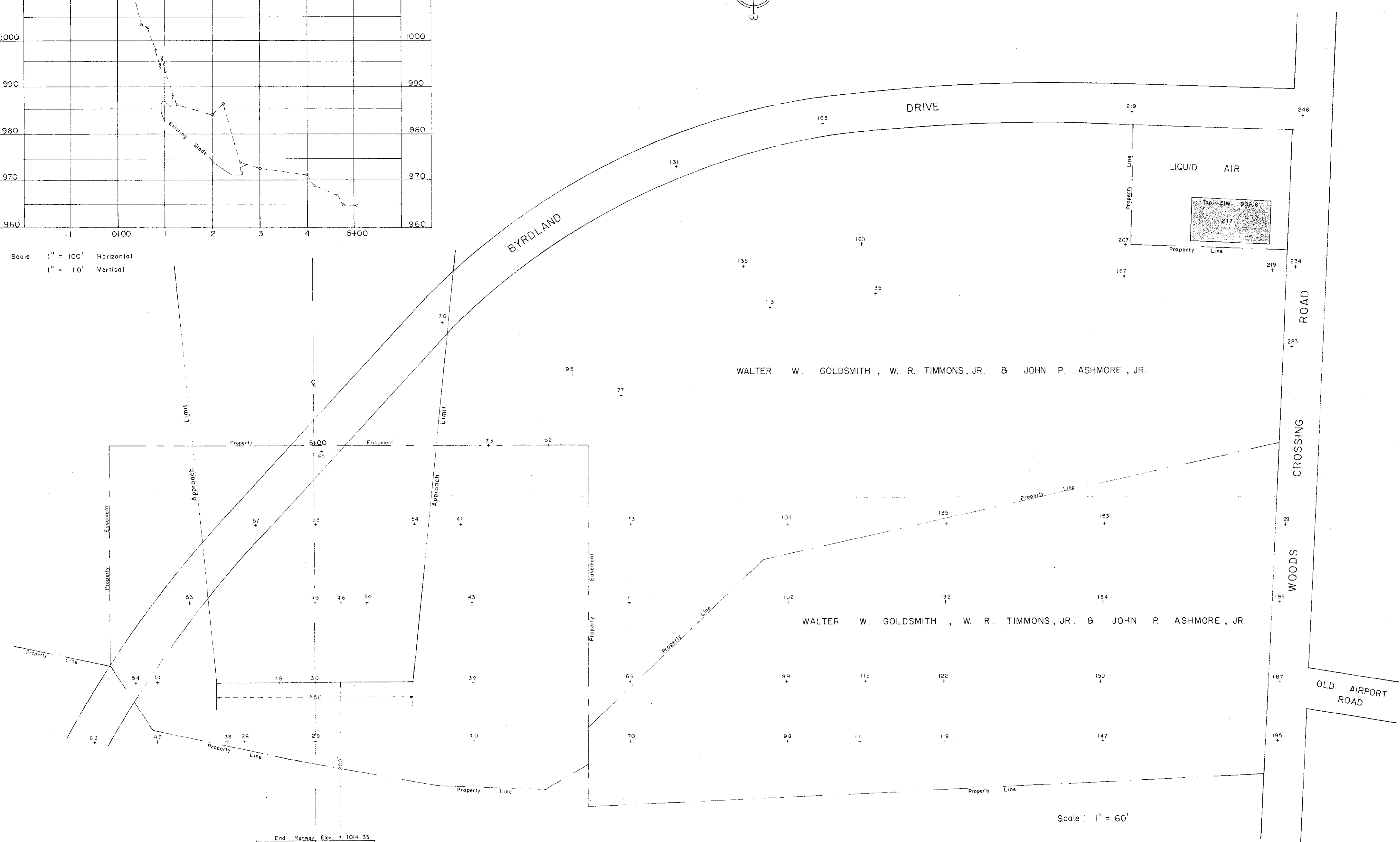

Scale: 1" = 60'

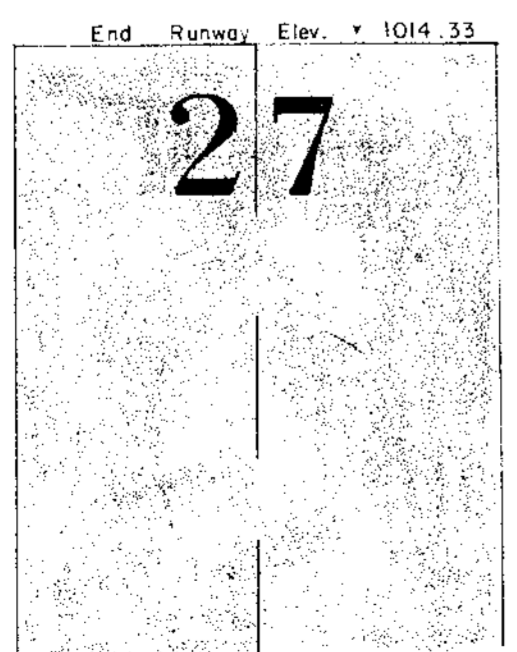

APPROACH LIMITS OF EAST RUNWAY
 GREENVILLE MUNICIPAL DOWNTOWN AIRPORT
 GREENVILLE, S. C.

DALTON & NEVES CO., ENGINEER
 GREENVILLE, S. C.
 March, 1977

NOTE: Numbers (i.e. 43) on plat indicate clearance between ground elevation and approach slope elevation. Approach elevations determined by using a 20:1 approach slope intercept by a 7:1 side transition slope.

MAY 19 1977

MAY 19 1977

MICROFILMED

MICROFILMED